

SECTION – A

1. This question consists of TWENTY FIVE sub-question (1.1 – 1.25) of ONE mark each. For each of these sub-questions, four possible answers (A, B, C and D) are given, out of which only one is correct. Answer each sub-question by darkening the appropriate bubble on the OBJECTIVE RESPONSE SHEET (ORS) using a soft HB pencil. Do not use the ORS for any rough work. You may like to use the Answer Book for any rough work, if needed.

1.1 The Voltage e_0 in the figure,

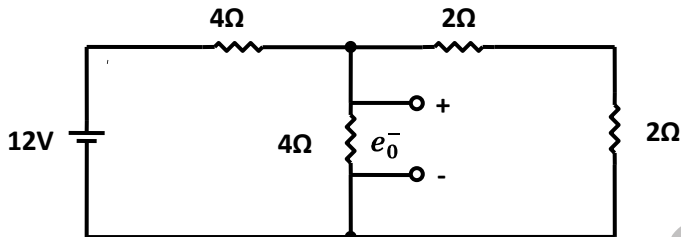

- (A) 2V (C) 4V
 (B) $\frac{4}{3}$ V (D) 8V

1.2 If each branch of a Delta circuit has impedance $\sqrt{3}Z$, then each branch of the equivalent Wye circuit has impedance.

- (A) $\frac{Z}{\sqrt{3}}$ (C) $3\sqrt{3}Z$
 (B) $3Z$ (D) $\frac{Z}{3}$

1.3 The transfer function of a system is given by $H(s) = \frac{1}{s^2(s-2)}$. The impulse response of the system is

- (A) $(t^2 * e^{-2t}) U(t)$ (C) $(te^{-2t}) U(t)$
 (B) $(t * e^{2t}) U(t)$ (D) $(te^{-2t}) U(t)$

(* denotes convolution, and $U(t)$ is unit step function)

1.4 The admittance parameter Y_{12} in the 2-point network in the figure,

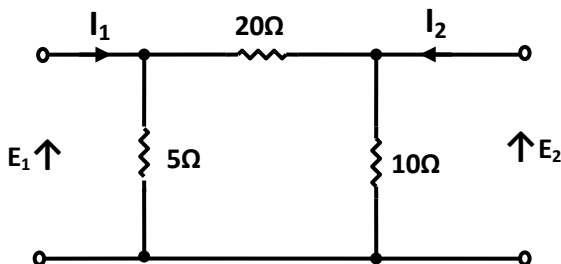

- (A) -0.2 mho
(B) 0.1 mho

- (C) -0.05 mho
(D) 0.05 mho

1.5 The region of convergence of the z-transform of a unit step function is

- (A) $|z| > 1$
(B) $|z| < 1$

- (C) (Real part of z) > 0
(D) (Real part of z) < 0

1.6 The current gain of a BJT is

- (A) $g_m r_o$
(B) $\frac{g_m}{r_o}$

- (C) $g_m r_\pi$
(D) $\frac{g_m}{r_\pi}$

1.7 MOSFET can be used as a

- (A) current controlled capacitor
(B) voltage controlled capacitor

- (C) current controlled inductor
(D) voltage controlled inductor

1.8 The effective channel length of a MOSFET in saturation decreases with increase in

- (A) gate voltage
(B) drain voltage

- (C) source voltage
(D) body voltage

1.9 The ideal OP-AMP has the following characteristics.

- (A) $R_i = \infty, A = \infty, R_o = 0$
(B) $R_i = 0, A = \infty, R_o = 0$

- (C) $R_i = \infty, A = \infty, R_o = \infty$
(D) $R_i = 0, A = \infty, R_o = \infty$

1.10 The 2's complement representation of -17 is

- (A) 01110
(B) 01111

- (C) 11110
(D) 10001

1.11 Consider the following two statements:

Statement 1: A stable multivibrator can be used for generating square wave.

Statement 2: B stable multivibrator can be used for storing binary information.

- (A) Only statement 1 is correct
(B) Only statement 2 is correct
(C) Both the statements 1 and 2 are correct
(D) Both the statements 1 and 2 are incorrect.

1.12 For the ring oscillator shown in the figure, the propagation delay of each inverter is 100 pico sec. What is the fundamental frequency of the oscillator output?

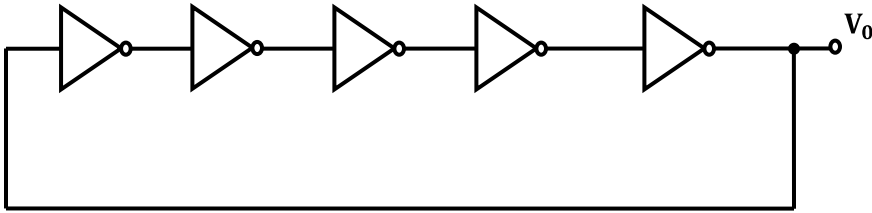

- (A) 10 MHz
- (B) 100 MHz
- (C) 1 GHz
- (D) 2 GHz

1.13 An 8085 microprocessor based system uses a $4K \times 8$ bit RAM whose starting address is AA00 H. The address of the last byte in this RAM is

- (A) 0FFF H
- (B) 1000 H
- (C) B9FF H
- (D) BA00 H

1.14 The equivalent of the block diagram in the figure, given in

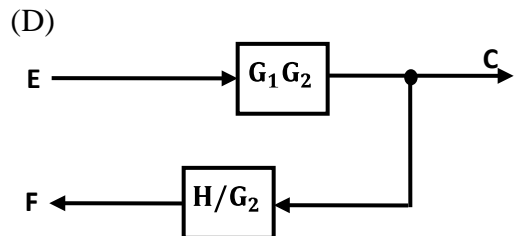
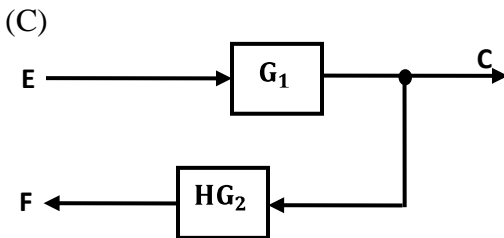
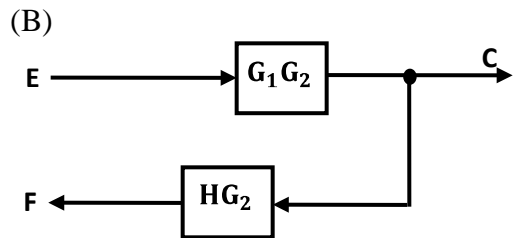
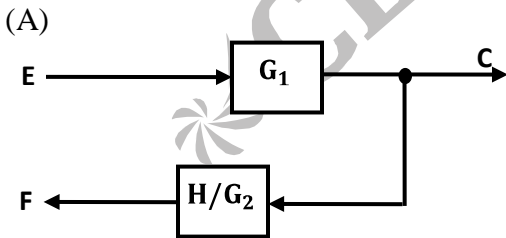
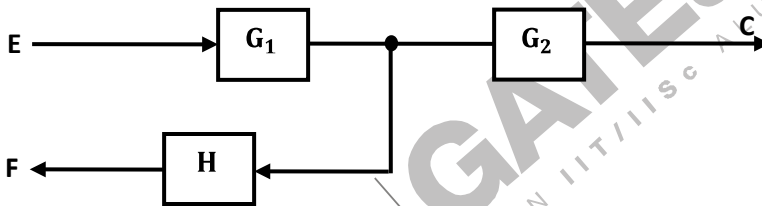

- 1.15 If the characteristics equation of a closed-loop system is $s^2 + 2s + 2 = 0$, then the system is
 (A) Overdamped (C) Underdamped
 (B) Critically damped (D) Undamped
- 1.16 The root-locus diagram for a closed-loop feedback system is shown in the figure is. The system is overdamped.

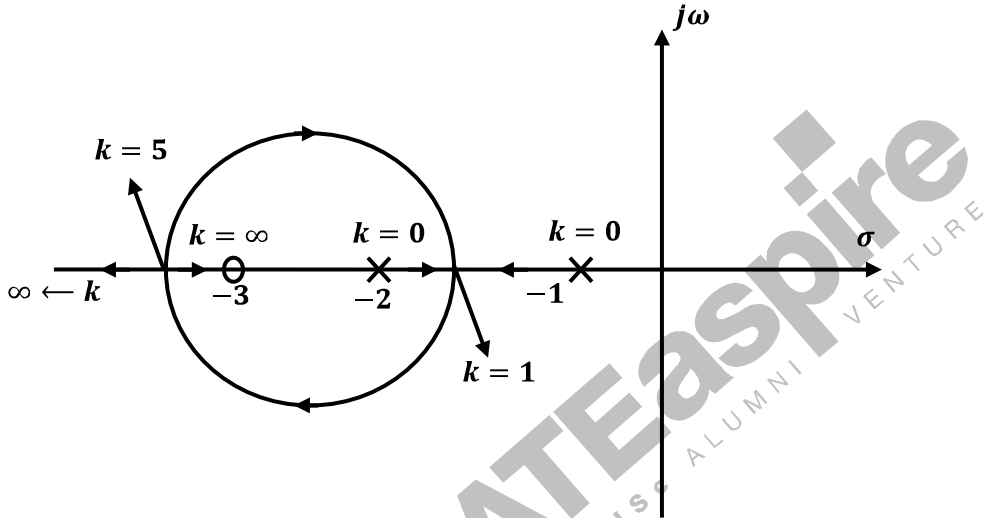

- (A) only if $0 \leq K \leq 1$ (C) only if $K > 5$
 (B) only if $1 < K < 5$ (D) if $0 \leq K < 1$ or $K > 5$
- 1.17 The Nyquist plot for the open-loop transfer function $G(s)$ of a unity negative feedback system is shown in the figure, if $G(s)$ has no pole in the right-half of s -plane, the number of roots of the system characteristic equation in the right-half of s -plane is

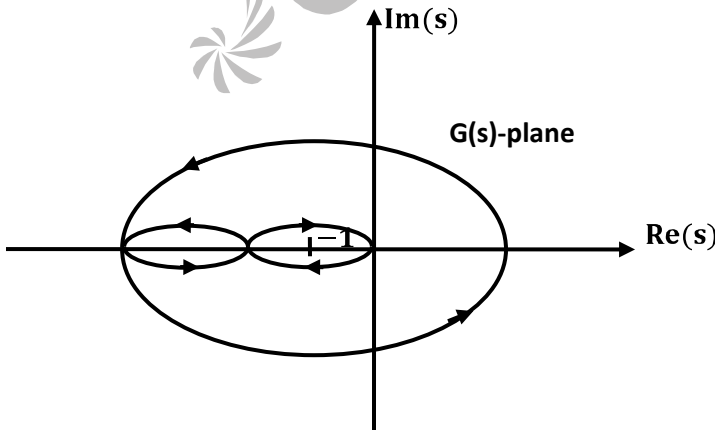

- (A) 0 (C) 2
 (B) 1 (D) 3

- 1.18 Let $\delta(t)$ denote the delta function. The value of the integral $\int_{-\infty}^{\infty} \delta(t) \cos\left(\frac{3t}{2}\right) dt$ is
- (A) 1
 - (B) -1
 - (C) 0
 - (D) $\frac{\pi}{2}$
- 1.19 A bandlimited signal is sampled at the Nyquist rate. The signal can be recovered by passing the samples through
- (A) an RC filter
 - (B) an envelope detector
 - (C) a PLL
 - (D) an ideal low-pass filter with the appropriate bandwidth.
- 1.20 The PDF of a Gaussian random variable X is given by $P_X(x) = \frac{1}{3\sqrt{2\pi}} e^{-\frac{(x-4)^2}{18}}$. The probability of the event $\{X=4\}$ is
- (A) $\frac{1}{2}$
 - (B) $\frac{1}{3\sqrt{2\pi}}$
 - (C) 0
 - (D) $\frac{1}{4}$
- 1.21 If a signal $f(t)$ has energy E , the energy of the signal $f(2t)$ is equal to
- (A) E
 - (B) $\frac{E}{2}$
 - (C) $2E$
 - (D) $4E$
- 1.22 A transmission line is distortionless if
- (A) $RL = \frac{1}{GC}$
 - (B) $RL = GC$
 - (C) $LG = RC$
 - (D) $RG = LC$
- 1.23 If a plane electromagnetic wave satisfies the equation $\frac{\partial^2 E_x}{\partial z^2} = c^2 \frac{\partial^2 E_x}{\partial t^2}$, the wave propagates in the
- (A) x -direction
 - (B) z -direction
 - (C) y -direction

(D) xy plane at an angle of 45° between the x and z directions

1.24 The phase velocity of waves propagating in a hollow metal waveguide is

- (A) greater than the velocity of light in free space.
- (B) less than the velocity of light in free space.
- (C) equal to the velocity of light in free space.
- (D) equal to the group velocity

1.25 The dominant mode in a rectangular waveguide is TE₁₀, because this mode has

- (A) no attenuation
- (B) no cut-off
- (C) no magnetic field component
- (D) the higher cut-off wavelength

2. This question consists of TWENTY FIVE sub-questions (2.1 – 2.25) of TWO marks each. For each of these sub-questions, four possible answers (A, B, C and D) are given, out of which only one is correct. Answer each sub-question by darkening the appropriate bubble on the OBJECTIVE RESPONSE SHEET (ORS) using a soft HB pencil. Do not use the ORS for any rough work. You may like to use the Answer Book for any rough work, if needed.

2.1 The voltage e_0 in the figure,

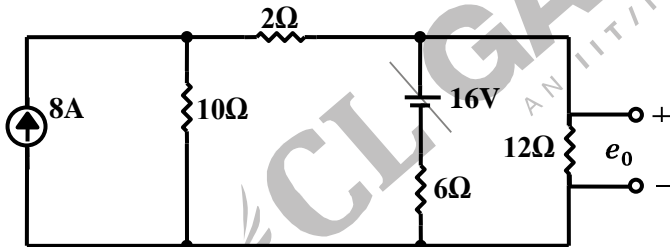

- (A) 48V
- (B) 24V
- (C) 36V
- (D) 28V

2.2 In the figure, the value of the load resistor R which maximizes the power delivered to it is

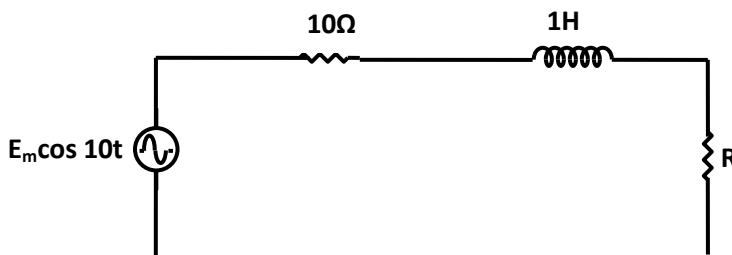

- (A) 14.14Ω
- (B) 10 Ω

- (C) 200 Ω
- (D) 28.28 Ω

2.3 When the angular frequency ω in the figure, varied from 0 to ∞ , the locus of the current phasor I_2 is given by

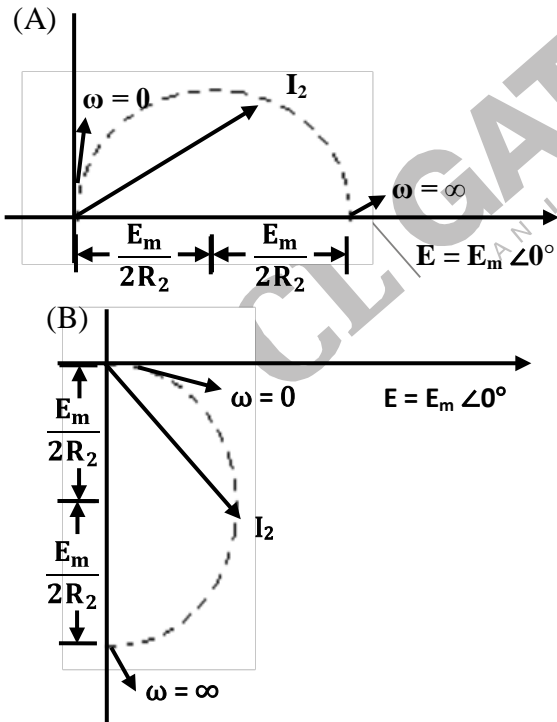
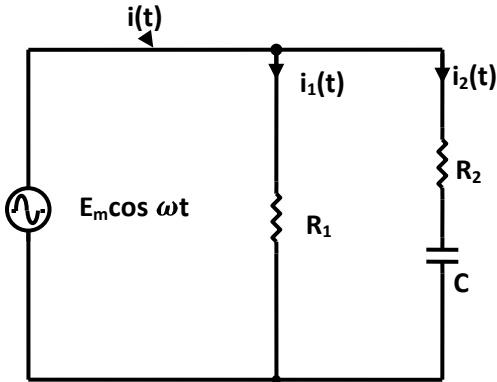

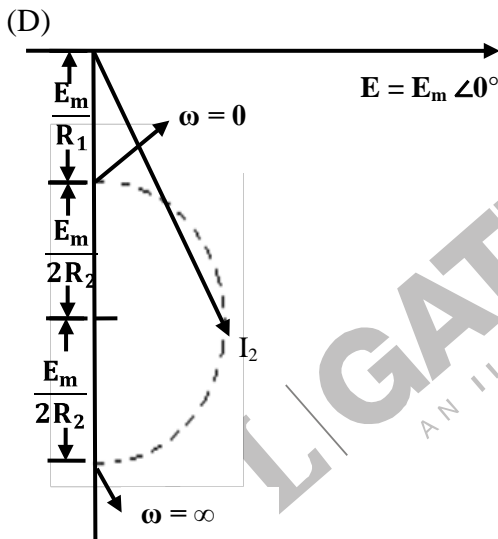
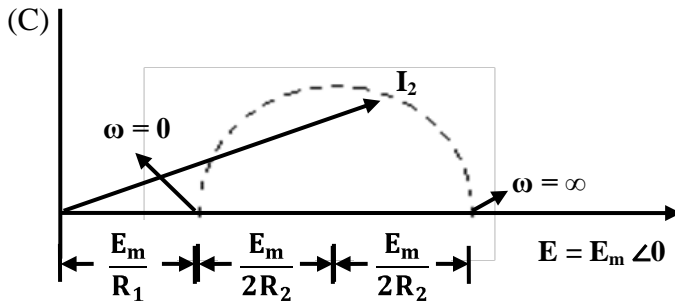

2.4 The Z parameters Z_{11} and Z_{21} for the 2-port network in the figure,

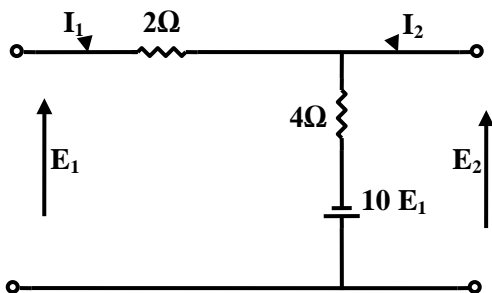

(A) $Z_{11} = -\frac{6}{11}\Omega$; $Z_{21} = \alpha \frac{16}{11}\Omega$;

(C) $Z_{11} = \frac{6}{11}\Omega$; $Z_{21} = -\frac{16}{11}\Omega$;

(B) $Z_{11} = \frac{6}{11}\Omega$; $Z_{21} = \frac{4}{11}\Omega$;

(D) $Z_{11} = \frac{4}{11}\Omega$; $Z_{21} = \frac{4}{11}\Omega$;

2.5 An npn BJT has $g_m = 38\text{ m A/V}$, $C_{\mu} = 10^{-14}\text{ F}$, $C_{\pi} = 4 \times 10^{-13}\text{ F}$, and DC current gain $\beta_0 = 90$. For this transistor f_T and f_{β} are

(A) $f_T = 1.64 \times 10^8\text{ Hz}$ and $f_{\beta} = 1.47 \times 10^{10}\text{ Hz}$

(B) $f_T = 1.47 \times 10^{10}\text{ Hz}$ and $f_{\beta} = 1.64 \times 10^8\text{ Hz}$

(C) $f_T = 1.33 \times 10^{12}\text{ Hz}$ and $f_{\beta} = 1.47 \times 10^{10}\text{ Hz}$

(D) $f_T = 1.47 \times 10^{10}\text{ Hz}$ and $f_{\beta} = 1.33 \times 10^{12}\text{ Hz}$

2.6 The transistor shunt regulator shown in the figure has a regulated output voltage of 10 V , when the input varies from 20 V to 30 V . The relevant parameters for the zener diode and the transistor are: $V_Z = 9.5\text{ V}$, $V_{SE} = 0.3\text{ V}$, $\beta = 99$. Neglect the current through R_B . Then the maximum power dissipated in the zener diode (P_Z) and the transistor (P_T) are

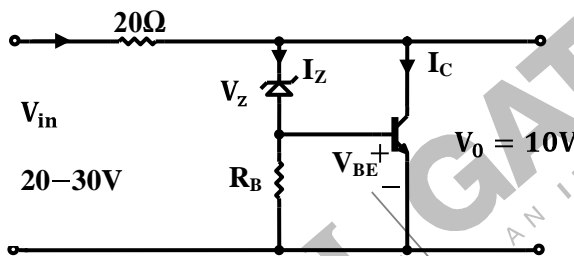

(A) $P_Z = 75\text{ mW}$, $P_T = 7.9\text{ W}$

(C) $P_Z = 95\text{ mW}$, $P_T = 9.9\text{ W}$

(B) $P_Z = 85\text{ mW}$, $P_T = 8.9\text{ W}$

(D) $P_Z = 115\text{ mW}$, $P_T = 11.9\text{ W}$

2.7 The oscillator circuit shown in the figure,

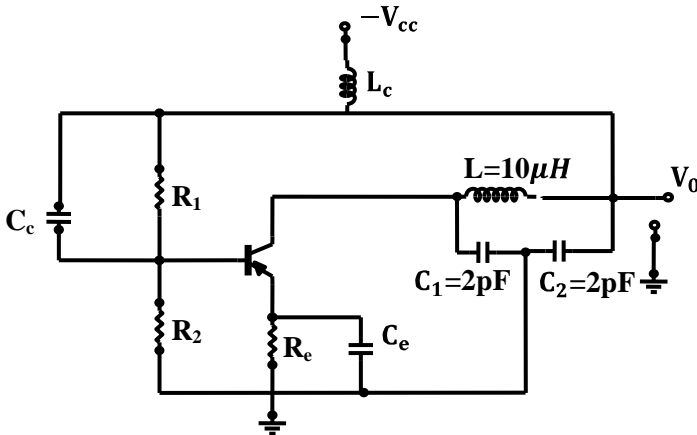

- (A) Hartley oscillator with $f_{\text{oscillation}} = 79.6 \text{ MHz}$
 - (B) Colpitts oscillator with $f_{\text{oscillation}} = 79.6 \text{ MHz}$
 - (C) Hartley oscillator with $f_{\text{oscillation}} = 159.2 \text{ MHz}$
 - (D) Colpitts oscillator with $f_{\text{oscillation}} = 159.2 \text{ MHz}$
- 2.8 The inverting OP – AMP shown in the figure has an open-loop gain of 100. The closed-loop gain $\frac{v_o}{v_s}$ is

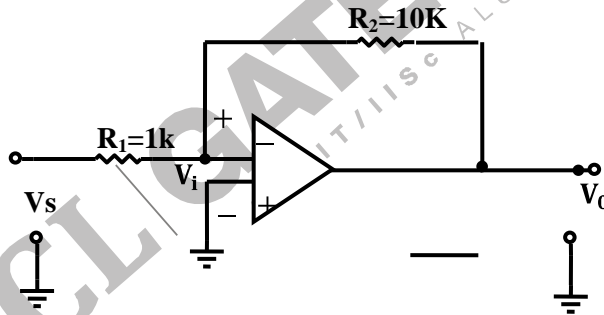

2.9 In the figure, assume the OP – AMPs to be ideal. The output v_o of the circuit is

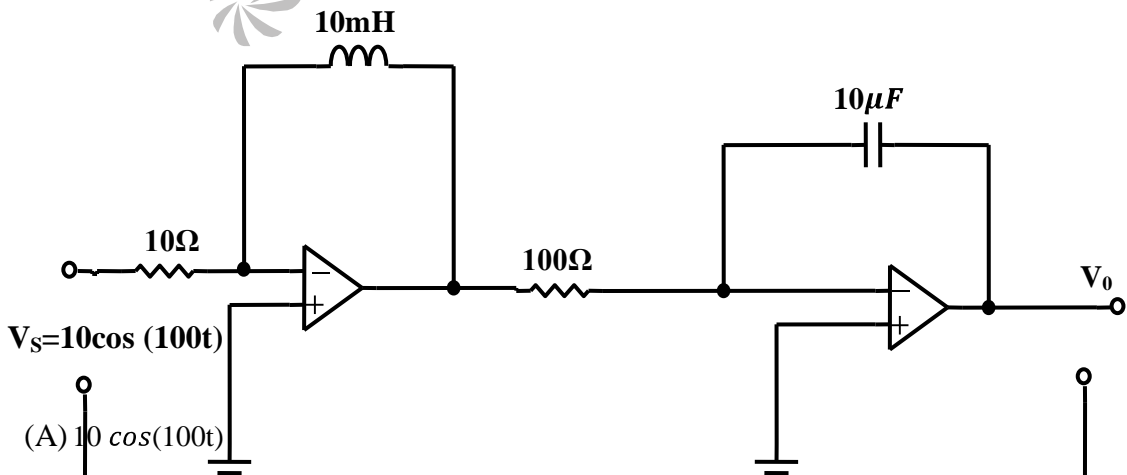

- (A) $10 \cos(100t)$

- (B) $10 \int_0^t \cos(100 \tau) d\tau$
- (C) $10^{-4} \int_0^t \cos(100\tau) d\tau$
- (D) $10^{-4} \frac{d}{dt} \cos(100t)$

2.10 In the figure, the LED

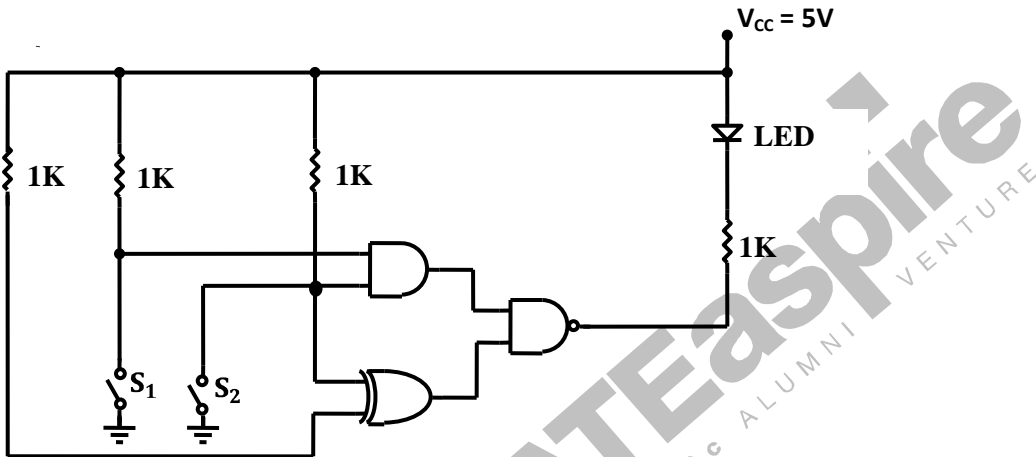

- (A) emits light when both S_1 and S_2 are closed.
 - (B) emits light when both S_1 and S_2 are open.
 - (C) emits light when only of S_1 or S_2 is closed.
 - (D) does not emit light, irrespective of the switch positions.
- 2.11 In the TTL circuit in the figure, S_2 to S_0 are select lines and X_7 to X_0 are input lines. S_0 and X_0 are LSBs. The output Y is

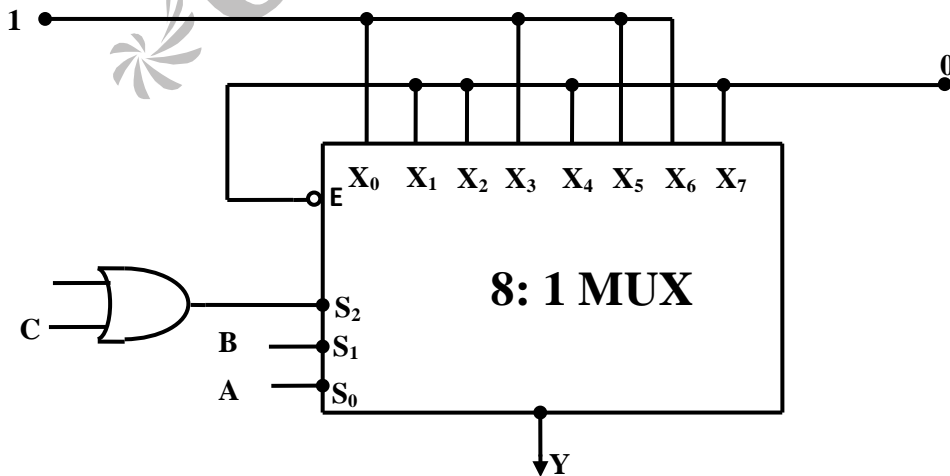

(A) indeterminate

(C) $\overline{A \oplus B}$

(B) $A \oplus B$

(D) $\overline{C} \cdot (\overline{A \oplus B}) + C \cdot (A \oplus B)$

2.12 The digital block in the figure, realized using two positive edged triggered D-flip-flops. Assume that for $t < t_0, Q_1 = Q_2 = 0$. The circuit in the digital block is given by

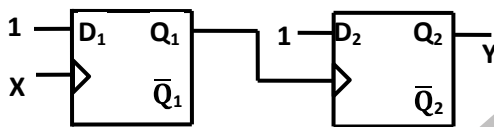
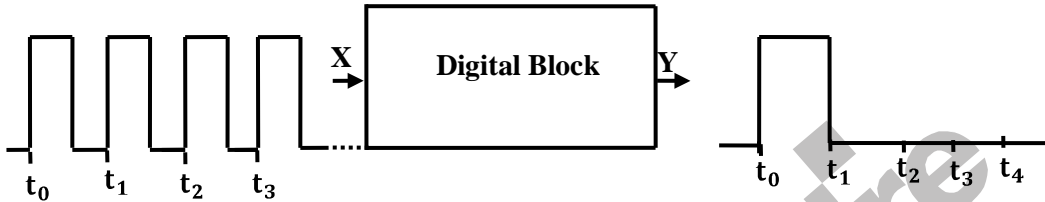

(A) Fig. 2.12(a)

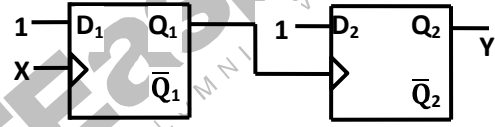

(B) Fig. 2.12(b)

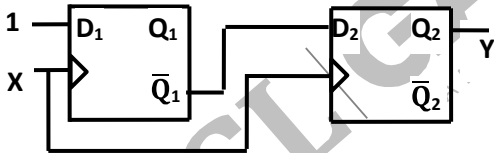

(C) Fig. 2.12(c)

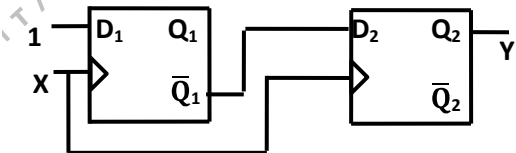

(D) Fig. 2.12(d)

2.13 In the DRAM cell in the figure is the V_t of the NMOSFET is 1 V. For the following three combinations of WL and BL voltages.

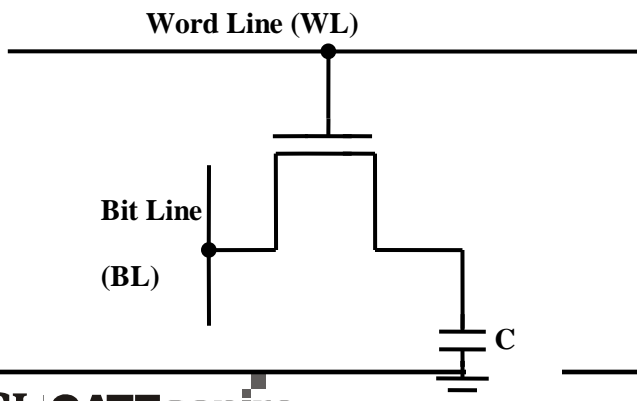

- (A) 5V; 3V; 7V
(B) 4V; 3V; 4V

- (C) 5V; 5V; 5V
(D) 4V; 4V; 4V

2.14 The impulse response functions of four linear systems S_1, S_2, S_3, S_4 are given respectively by

$$h_1(t) = 1 \quad h_2(t) = U(t)$$

$$h_3(t) = \frac{U(t)}{t+1} \quad h_4(t) = e^{-3t}U(t)$$

Where $U(t)$ is the unit step function. Which of these systems is time invariant, causal, and stable?

- (A) S_1 (C) S_3
(B) S_2 (D) S_4

2.15 An electrical system and its signal-flow graph representations are shown in the figure respectively. The values of G_2 and H , respectively, are

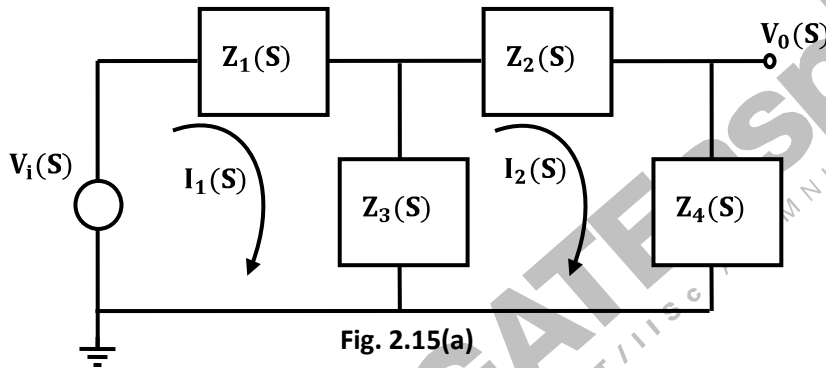

Fig. 2.15(a)

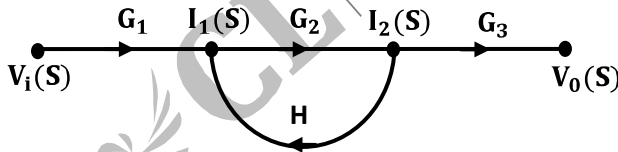

Fig. 2.15(b)

- (A) $\frac{Z_3(S)}{Z_2(S)+Z_3(S)+Z_4(S)}$, $\frac{-Z_3(S)}{Z_1(S)+Z_3(S)}$ (C) $\frac{Z_3(S)}{Z_2(S)+Z_3(S)+Z_4(S)}$, $\frac{Z_3(S)}{Z_1(S)+Z_3(S)}$
(B) $\frac{-Z_3(S)}{Z_2(S)-Z_3(S)+Z_4(S)}$, $\frac{-Z_3(S)}{Z_1(S)+Z_3(S)}$ (D) $\frac{-Z_3(S)}{Z_2(S)-Z_3(S)+Z_4(S)}$, $\frac{Z_3(S)}{Z_1(S)+Z_3(S)}$

2.16 The open-loop DC gain of a unity negative feedback system with closed-loop transfer function

$$\frac{s+4}{s^2+7s+13} \text{ is}$$

- (A) $\frac{4}{13}$
(B) $\frac{4}{9}$

- (C) 4
(D) 13

2.17 The feedback control system in the figure is stable.

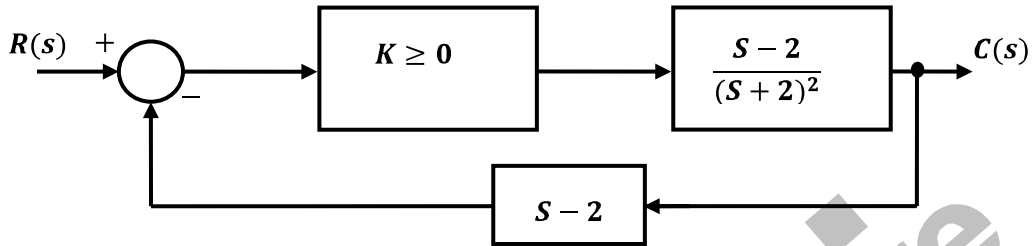

- (A) for all $K \geq 0$
 (B) only if $K \geq 1$
 (C) only if $0 \leq K < 1$
 (D) only if $0 \leq K \leq 1$
- 2.18 A video transmission system transmits 625 picture frames per second. Each frame consists of a 400×400 pixel grid with 64 intensity levels per pixel. The data rate of the system is
 (A) 16 Mbps (C) 600 Mbps
 (B) 100 Mbps (D) 6.4 Gbps
- 2.19 The Nyquist sampling interval, for the signal $\sin c(700t) + \sin c(500t)$ is
 (A) $\frac{1}{350}$ sec (C) $\frac{1}{700}$ sec
 (B) $\frac{\pi}{350}$ sec (D) $\frac{\pi}{175}$ sec
- 2.20 During transmission over a communication channel, bit errors occur independently with probability p . If a block of n bits is transmitted, the probability of at most one bit error is equal to
 (A) $1 - (1-p)^n$
 (B) $p + (n-1)(1-p)$
 (C) $np(1-p)^{n-1}$
 (D) $(1-p)^n + np(1-p)^{n-1}$
- 2.21 The PSD and the power of a signal $g(t)$ are, respectively, $S_g(\omega)$ and P_g . The PSD and the power of the signal $ag(t)$ are, respectively,
 (A) $a^2 S_g(\omega)$ and $a^2 P_g$
 (B) $a^2 S_g(\omega)$ and $a P_g$

- (C) $aS_g(\omega)$ and a^2P_g
(D) $aS_g(\omega)$ and aP_g
- 2.22 A material has conductivity of 10^{-2} mho/m and a relative permittivity of 4. The frequency at which the conduction current in the medium is equal to the displacement current is
(A) 45MHz (C) 450 MHz
(B) 90 MHz (D) 900 MHz
- 2.23 A uniform plane electromagnetic wave incident normally on a plane surface of a dielectric material is reflected with a VSWR of 3. What is the percentage of incident power that is reflected?
(A) 10% (C) 50%
(B) 25% (D) 75%
- 2.24 A medium wave radio transmitter operating at a wavelength of 492 m has a tower antenna of height 124 m. What is the radiation resistance of the antenna?
(A) 25 Ω (C) 50 Ω
(B) 36.5 Ω (D) 73 Ω
- 2.25 In a uniform linear array, four isotropic radiating elements are spaced $\frac{\lambda}{4}$ apart. The progressive phase shift between the elements required for forming the main beam at 60° off the end-fire is
(A) $-\pi$ radians
(B) $-\frac{\pi}{2}$ radians
(C) $-\frac{\pi}{4}$ radians
(D) $-\frac{\pi}{8}$ radians

SECTION – B (75 Marks)

This section consists of TWENTY questions of FIVE marks each. ANY FIFTEEN out of these questions have to be answered in the Answer Book provided.

3. For the circuit shown in the figure, determine the phasors E_2 , E_0 , I , and I_1 .

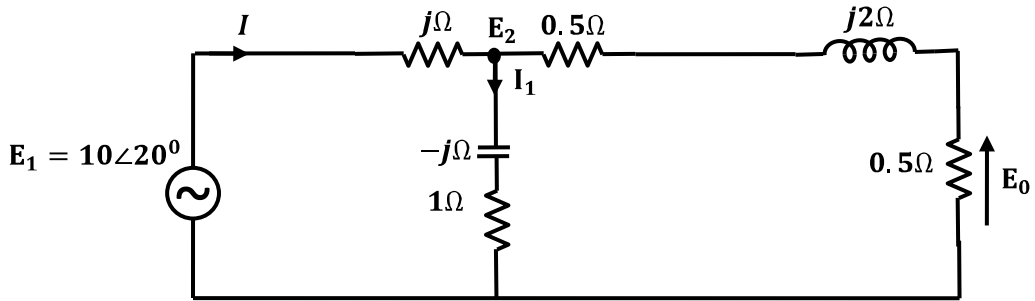

4. The circuit shown in the figure, operating in steady-state with switch S_1 closed. The switch S_1 is opened at $t = 0$

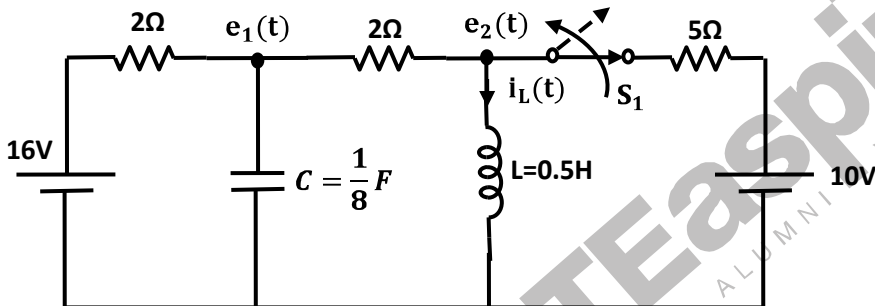

- (A) Find $i_L(0^+)$.
 (B) Find $e_1(0^+)$.
 (C) Using nodal equations and Laplace transform approach, find an expression for the voltage across the capacitor for all $t > 0$.
5. The admittance parameters of a 2-port network shown in the figure, given by $Y_{11} = 2$ mho, $Y_{12} = -0.5$ mho, $Y_{21} = 4.8$ mho, $Y_{22} = 1$ mho. The output port is terminated with a load admittance $Y_L = 0.2$ mho. Find E_2 for each of the following conditions.



- (A) $E_1 = 10\angle 0^\circ V$
 (B) $I_1 = 10\angle 0^\circ A$
 (C) A source $10\angle 0^\circ V$ in series with a 0.25Ω resistor is connected to the input port.
6. For the circuit shown in the figure. D_1 and D_2 are identical diodes with ideality factor of unity. The thermal voltage $V_T = 25mV$.

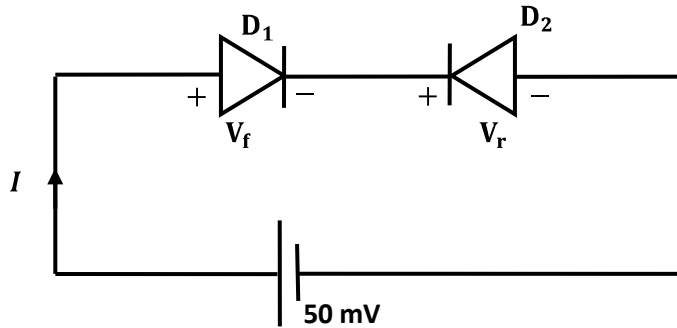

- (A) Calculate V_f and V_r .
- (B) If the reverse saturation current, I_s , for the diode is 1 pA , then compute the current I through the circuit.
7. An emitter-follower amplifier is shown in the figure, Z_i for the impedance looking into the base of the transistor and Z_o is the impedance looking into the emitter of the transistor.

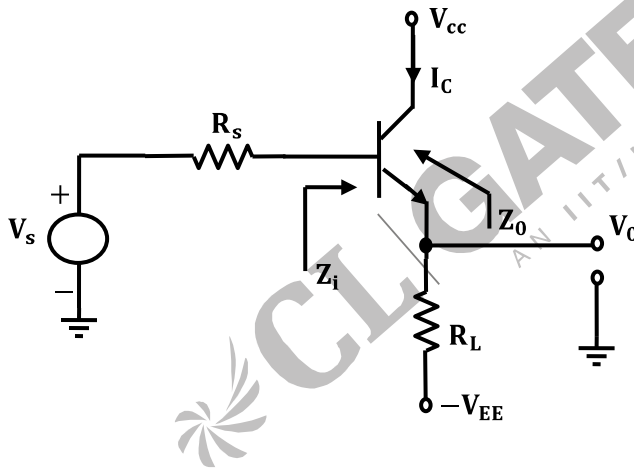

- (A) Draw the small signal equivalent circuit of the amplifier.
- (B) Obtain an expression for Z_i .
- (C) Obtain an expression for Z_o .
- (D) Determine Z_i and Z_o if a capacitor C_L is connected across R_L .
8. Assume that the OP-AMP in the figure, ideal

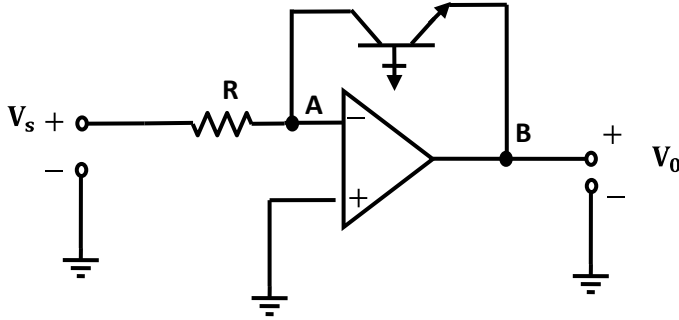

- (A) Obtain an expression for v_0 in terms of v_s , R , and the reverse saturation current I_s of the transistor.
- (B) If $R = 1\Omega$, $I_s = 1\text{pA}$ and the thermal voltage $V_T = 25\text{mV}$, then what is the value of the output voltage v_0 for an input voltage $v_s = 1\text{V}$?
- (C) Suppose that the transistor in the feedback path is replaced by a p-n junction diode with a reverse saturation current of I_s . The p -side of the diode is connected to node A and the n -side to node B. Then what is the expression for v_0 in terms of v_s , R and I_s ?
9. A monochrome video signal that ranges from 0 to 8V, is digitized using an 8-bit ADC.
- (A) Determine the resolution of the ADC in V/bit.
- (B) Calculate the mean squared quantization error.
- (C) Suppose the ADC is counter controlled. The counter is upcount and positive edge triggered with clock frequency 1 MHz. What is the time taken in seconds to get a digital equivalent of 1.59V?
10. In the figure, the output of the oscillator, V_1 has 10V peak amplitude with zero DC value. The transfer characteristic of the Schmitt inverter is also shown in the figure is. Assume that the JK flip-flop is reset at time $t = 0$.

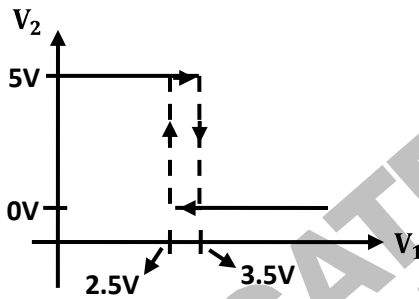
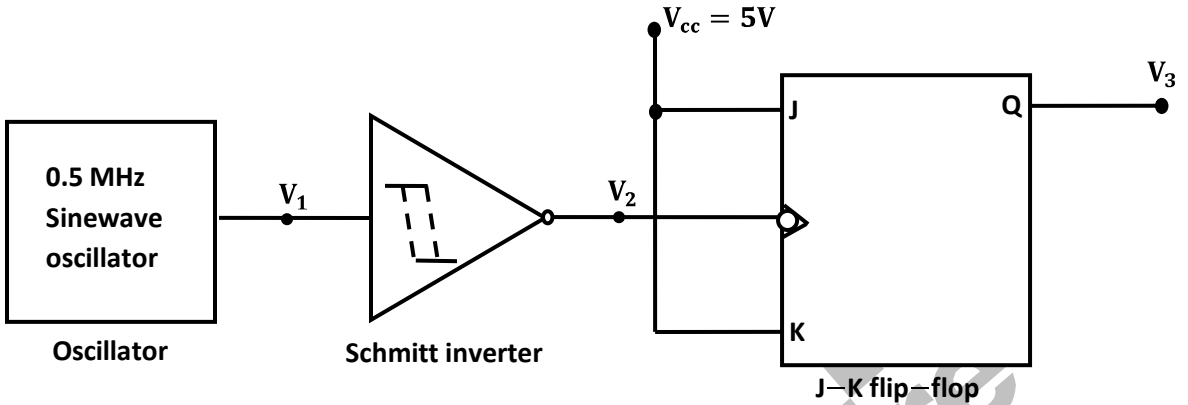

- (A) What is the period and duty cycle of the waveform V_2 ?
- (B) What is the period and duty cycle of the waveform V_3 ?
- (C) Sketch V_1 , V_2 and V_3 for the duration $0 \leq t \leq 6\mu s$. Clearly indicate the exact timings when the waveforms V_2 and V_3 make high-to-low and low-to-high transitions.
11. For the digital block shown in the figure the output $Y = f(S_3, S_2, S_1, S_0)$ where S_3 is MSB and S_0 is LSB. Y is given in terms of minterms as $Y = \sum m(1,5,6,7,11,12,13,15)$ and its complement is $\bar{Y} = \sum m(0, 2, 3, 4, 8, 9, 10, 14)$

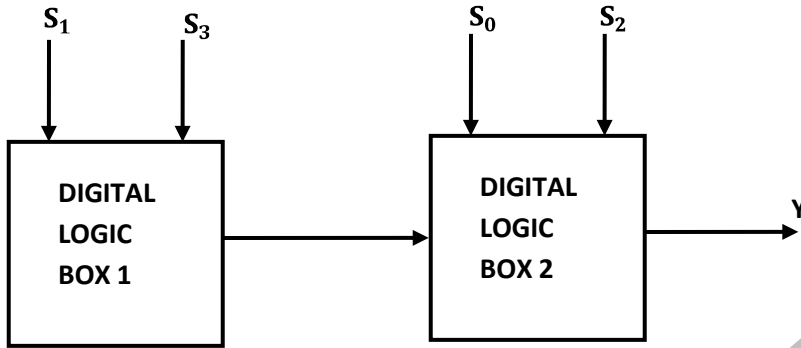

(a)

$S_3 S_2 \backslash S_1 S_0$	00	01	11	10
00				
01				
11				
10				

(b)

- (A) Enter the logical values in the given Karnaugh map in the figure, for the output Y.
- (B) Write down the expression for Y in sum-of-products from using minimum number of terms.
- (C) Draw the circuit for the digital logic boxes using four 2-input NAND gates only for each of the boxes.

12. Consider the following sequence of instructions for an 8085 microprocessor based system.

Memory Address	Instructions
FF00	MVI A, FFH
FF02	INR A
FF03	JC FF0C H
FF06	ORI A8H
FF08	JM FF15 H
FF0B	XRA A
FF0C	OUT PORT 1
FF0E	HLT

FF10	XRI	FF H
FF12	OUT	PORT2
FF14	HLT	
FF15	MVI A,	FF H
FF17	ADI	02 H
FF19	RAL	
FF1A	JZ	FF23 H
FF1D	JC	FF10 H
FF20	JNC	FF12 H
FF23	CMA	
FF24	OUT	PORT3
FF26	HLT	

- (A) If the program execution begins at the location FF00 H, write down the sequence of instructions which are actually executed till a HLT instruction. (Assume all flags are initially RESET).
- (B) Which of the three ports (PORT1, PORT2 and PORT3) will be loaded with data, and what is the bit pattern of the data?

13. A feedback control system is shown in figure,

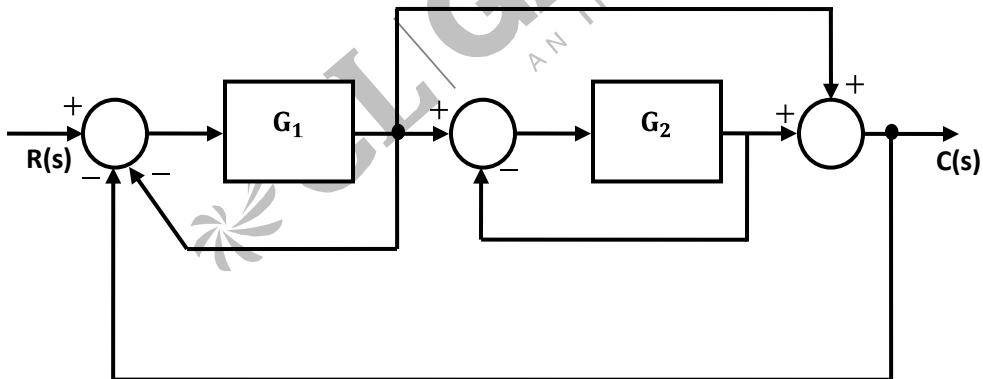

- (A) Draw the signal-flow graph that represents the system.
- (B) Find the total number of loops in the graph and determine the loop-gains of all the loops.
- (C) Find the number of all possible combinations of non-touching loops taken two at a time.
- (D) Determine the transfer function of the system using the signal-flow graph.

14. Consider the feedback control system shown in figure,

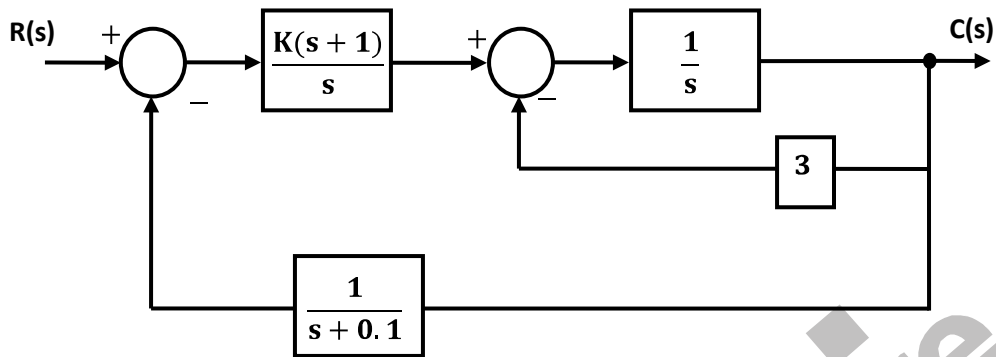

- (A) Find the transfer function of the system and its characteristic equation.
 (B) Use the Routh-Hurwitz criterion to determine the range of K for which the system is stable.
15. For the feedback control system shown in the figure, the process transfer function is $Gp(s) = \frac{1}{s(s+1)}$, and the complication factor of the power amplifier is $K \geq 0$. The design specifications required for the system, time constant is 1 sec and a damping ratio of 0.707.

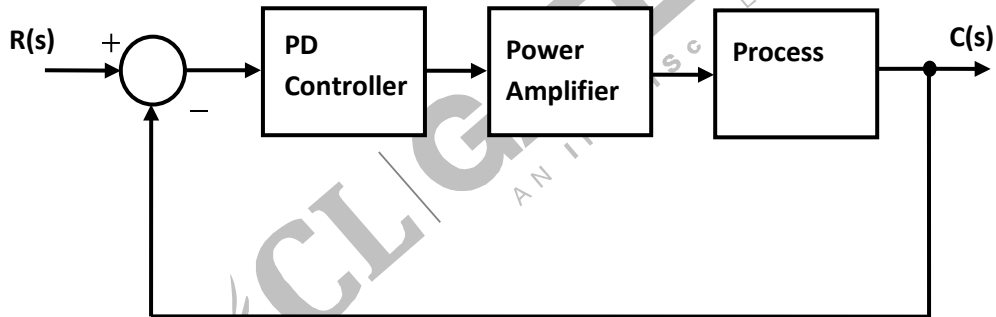

- (A) Find the desired locations of the closed-loop poles.
 (B) Write down the required characteristics equation for the system. Hence determine the PD controller transfer function $G_0(s)$ when $K = 1$.
 (C) Sketch the root-locus for the system.
16. The Fourier transform $G(\omega)$ of the signal $g(t)$ in the figure, given as $G(\omega) = \frac{1}{\omega^2} (e^{j\omega} - j\omega e^{j\omega} - 1)$. Using this information and the time-shifting and time-scaling properties, determine the Fourier transform of signals in the figure.

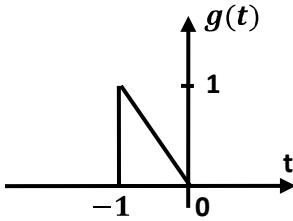

Fig. 16(A)

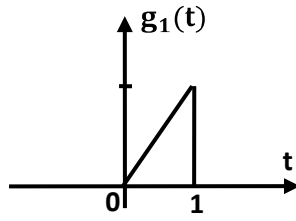

Fig. 16(B)

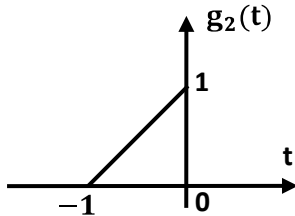

Fig. 16(C)

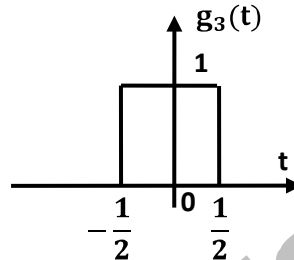
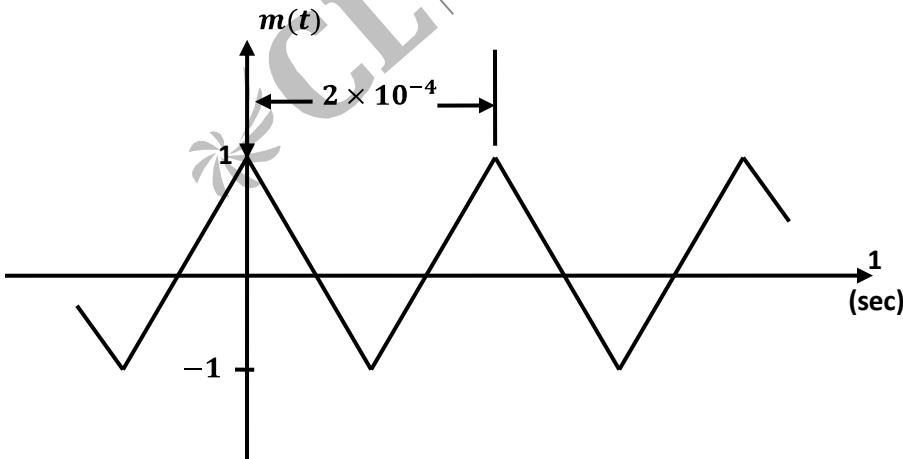
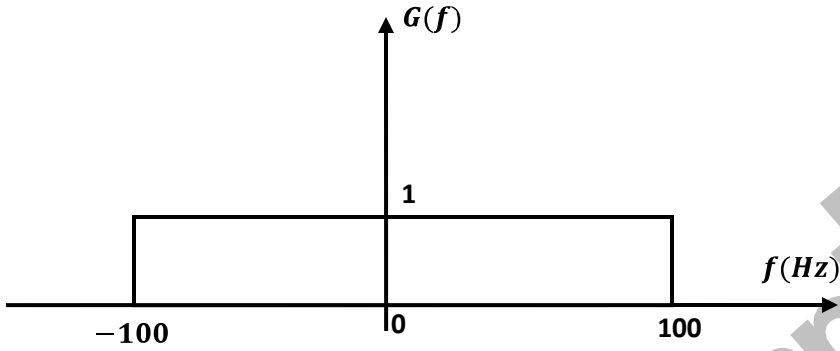

Fig. 16(D)

17. The periodic modulating signal $m(t)$ is shown in the figure. Using Carson's rule. Estimate B_{FM} (bandwidth of the FM signal) and B_{PM} (bandwidth of the PM signal) for $k_f = \pi \times 10^4$ and $k_p = \frac{\pi}{4}$. Assume the essential bandwidth of $m(t)$ to consist only up to and including the third harmonic.



18. A baseband signal $g(t)$ bandlimited to 100 Hz modulates a carrier of frequency f_0 Hz. The modulated signal $g(t) \cos 2\pi f t$ is transmitted over a channel whose input x and output y are related by $y = 2x + x^2$. The spectrum of $g(t)$ is shown in the figure. Sketch the spectrum of the transmitted signal and the spectrum of the received signal.



19. A periodic signal $g(t)$ is shown in the figure. Determine the PSD of $g(t)$.

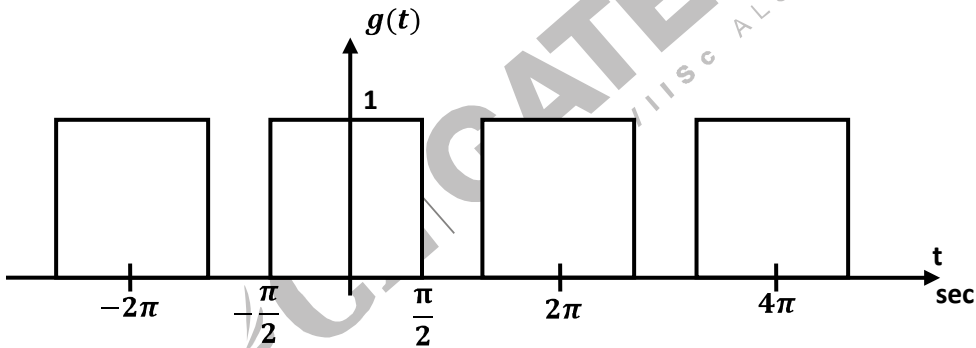

Fig. 19

20. A system of three electric charges lying in a straight line is in equilibrium. Two of the charges are positive with magnitudes Q and $2Q$, and are 50cm apart. Determine the sign, magnitude and position of the third charge.
21. A medium has a breakdown strength of 16 KV/m r.m.s. its relative permeability is 1.0 and relative permittivity is 4.0 A plane electromagnetic wave is transmitted through the medium. Calculate the maximum possible power flow density and the associated magnetic field.

22. A rectangular hollow metal waveguide has dimensions $a = 2.29\text{cm}$ and $b = 1.02\text{cm}$. Microwave power at 10 GHz is transmitted through the waveguide in the TE_{10} mode.
- (A) Calculate the cut-off wavelength and the guide wavelength for this mode.
 - (B) What are the other (TE or TM) modes that can propagate through the waveguide?
 - (C) If $a = b = 2.29\text{cm}$, what are the modes which can propagate through the waveguide?

